

## 7 Chemical Ionization

Mass spectrometrists have ever been searching for ionization methods softer than EI, because molecular weight determination is of key importance for structure elucidation. *Chemical ionization* (CI) is the first of the *soft ionization methods* we are going to discuss. Historically, field ionization (FI, Chap. 8) has been applied some years earlier, and thus CI can be regarded as the second soft ionization method introduced to analytical mass spectrometry. Several aspects of CI possess rather close similarity to EI making its discussion next to EI more convenient. CI goes back to experiments of Talrose in the early 1950s [1] and was developed to an analytically useful technique by Munson and Field in the mid-1960s. [2-5] Since then, the basic concept of CI has been extended and applied in numerous different ways, meanwhile providing experimental conditions for a wide diversity of analytical tasks. [5,6] The monograph by Harrison is especially recommended for further reading. [7]

**Note:** When a positive ion results from CI, the term may be used without qualification; nonetheless *positive-ion chemical ionization* (PICI) is frequently found in the literature. When negative ions are formed, the term *negative-ion chemical ionization* (NICI) should be used. [8]

### 7.1 Basics of Chemical Ionization

#### 7.1.1 Formation of Ions in Chemical Ionization

In chemical ionization new ionized species are formed when gaseous molecules interact with ions. Chemical ionization may involve the transfer of an electron, proton, or other charged species between the reactants. [8] These reactants are i) the neutral analyte M and ii) ions from a reagent gas.

CI differs from what we have encountered in mass spectrometry so far because *bimolecular processes* are used to generate analyte ions. The occurrence of bimolecular reactions requires a sufficiently large number of ion-molecule collisions during the dwelltime of the reactants in the ion source. This is achieved by significantly increasing the partial pressure of the reagent gas. Assuming reasonable collision cross sections and an ion source residence time of 1  $\mu\text{s}$ , [9] a molecule will undergo 30–70 collisions at an ion source pressure of about  $2.5 \times 10^2$  Pa. [10] The  $10^3$ – $10^4$ -fold excess of reagent gas also shields the analyte molecules effectively

from ionizing primary electrons which is important to suppress competing direct EI of the analyte. There are four general pathways to form ions from a neutral analyte M in CI:

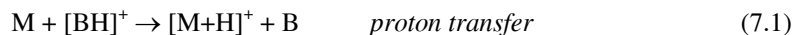

Although proton transfer is generally considered to yield protonated analyte molecules,  $[M+H]^+$ , acidic analytes may also form abundant  $[M-H]^+$  ions by protonating some other neutral. Electrophilic addition chiefly occurs by attachment of complete reagent ions to the analyte molecule, e.g.,  $[M+NH_4]^+$  in case of ammonia reagent gas. Hydride abstractions are abundant representatives of anion abstraction, e.g., aliphatic alcohols rather yield  $[M-H]^+$  ions than  $[M+H]^+$  ions. [11,12] Whereas reactions 7.1–7.3 result in even electron ions, charge exchange (Eq. 7.4) yields radical ions of low internal energy which behave similar to molecular ions in low-energy electron ionization (Chap. 5.1.5).

**Note:** It is commonplace to denote  $[M+H]^+$  and  $[M-H]^+$  ions as *quasimolecular ions* because these ions comprise the otherwise intact analyte molecule and are detected instead of a molecular ion when CI or other soft ionization methods are employed. Usually, the term is also applied to  $[M+\text{alkali}]^+$  ions created by other soft ionization methods.

### 7.1.2 Chemical Ionization Ion Sources

CI ion sources exhibit close similarity to EI ion sources (Chap. 5.2.1). In fact, modern EI ion sources can usually be switched to CI operation in seconds, i.e., they are constructed as *EI/CI combination ion sources*. Such a change requires the EI ion source to be modified according to the needs of holding a comparatively high pressure of reagent gas (some  $10^2$  Pa) without allowing too much leakage into the ion source housing. [13] This is accomplished by axially inserting some inner wall, e.g., a small cylinder, into the ion volume leaving only narrow holes for the entrance and exit of the ionizing primary electrons, the inlets and the exiting ion beam. The ports for the reference inlet, the gas chromatograph (GC) and the direct probe (DIP) need to be tightly connected to the respective inlet system during operation, i.e., an empty DIP is inserted even when another inlet actually provides the sample flow into the ion volume. The reagent gas is introduced directly into the ion volume to ensure maximum pressure inside at minimum losses to the ion source housing (Fig. 7.1). During CI operation, the pressure in the ion source housing typically rises by a factor of 20–50 as compared to the background pressure of the instrument, i.e., to  $5 \times 10^{-4}$ – $10^{-3}$  Pa. Thus, sufficient pumping

speed ( $\geq 200 \text{ l s}^{-1}$ ) is necessary to maintain stable operation in CI mode. The energy of the primary electrons is preferably adjusted to some 200 eV, because electrons of lower energy experience difficulties in penetrating the reagent gas.

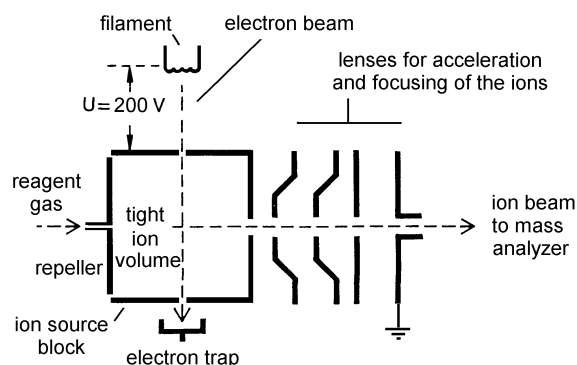

**Fig. 7.1.** Schematic layout of a chemical ionization ion source. Adapted from Ref. [14] by permission. © Springer-Verlag Heidelberg, 1991.

### 7.1.3 Sensitivity of Chemical Ionization

Ionization in CI is the result of one or several competing chemical reactions. Therefore, the sensitivity in CI strongly depends on the conditions of the experiment. In addition to primary electron energy and electron current, the reagent gas, the reagent gas pressure, and the ion source temperature have to be stated with the sensitivity data to make a comparison. Modern magnetic sector instruments are specified to have a sensitivity of about  $4 \times 10^{-8} \text{ C } \mu\text{g}^{-1}$  for the  $[\text{M}+\text{H}]^+$  quasi-molecular ion of methylstearate,  $m/z$  299, at  $R = 1000$  in positive-ion CI mode. This is approximately one order of magnitude less than for EI.

## 7.2 Chemical Ionization by Protonation

### 7.2.1 Source of Protons

The occurrence of  $[\text{M}+\text{H}]^+$  ions due to bimolecular processes between ions and their neutral molecular counterparts is called *autoprotonation* or *self-CI*. Usually, autoprotonation is an unwanted phenomenon in EI-MS.  $[\text{M}+1]$  ions from autoprotonation become more probable with increasing pressure and with decreasing temperature in the ion source. Furthermore, the formation of  $[\text{M}+1]$  ions is promoted if the analyte is of high volatility or contains acidic hydrogens. Thus, self-CI can mislead mass spectral interpretation either by leading to an overestimation of the number of carbon atoms from the  $^{13}\text{C}$  isotopic peak (Chap. 3.2.1) or by

indicating a by 1 u higher molecular mass (Fig. 7.6 and cf. *nitrogen rule* Chap. 6.2.5). However, in CI-MS with methane or ammonia reagent gas, for example, the process of autoprotection is employed to generate the reactant ions.

**Note:** The process  $M^* + X \rightarrow MX^{++} + e^-$ , i.e., ionization of internally excited molecules upon interaction with other neutrals is known as *chemi-ionization*. Chemi-ionization is different from CI in that there is no ion-molecule reaction involved [8,15] (cf. Penning ionization, Chap. 2.2.1).

### 7.2.2 Methane Reagent Gas Plasma

The EI mass spectrum of methane has already been discussed (Chap. 6.1). Raising the partial pressure of methane from the standard value in EI of about  $10^{-4}$  Pa to  $10^2$  Pa significantly alters the resulting mass spectrum. [1] The molecular ion,  $CH_4^{++}$ ,  $m/z$  16, almost vanishes and a new species,  $CH_5^+$ , is detected at  $m/z$  17 instead. [16] In addition some ions at higher mass occur, the most prominent of which may be assigned as  $C_2H_5^+$ ,  $m/z$  29, [17,18] and  $C_3H_5^+$ ,  $m/z$  41 (Fig. 7.2). The positive ion CI spectrum of methane can be explained as the result of competing and consecutive bimolecular reactions in the ion source: [4,6,10]

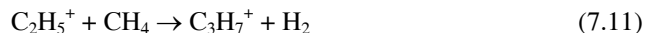
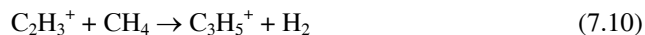
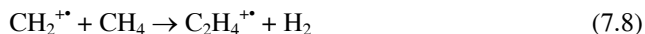
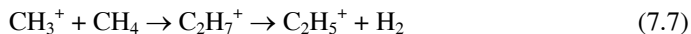
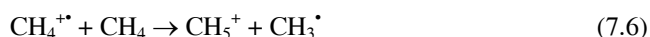

The relative abundances of these product ions change dramatically as the ion source pressure increases from EI conditions to 25 Pa. Above 100 Pa, the relative concentrations stabilize at the levels represented by the CI spectrum of methane reagent gas (Fig. 7.3). [4,19] Fortunately, the ion source pressure of some  $10^2$  Pa in CI practice is in the plateau region of Fig. 7.3, thereby ensuring reproducible CI conditions. The influence of the ion source temperature is more pronounced than in EI because the high collision rate rapidly effects a thermal equilibrium.

**Note:** Although the temperature of the ionized reagent gas is by far below that of a plasma, the simultaneous presence of free electrons, protons, numerous ions and radicals lead to its description as a *reagent gas plasma*.

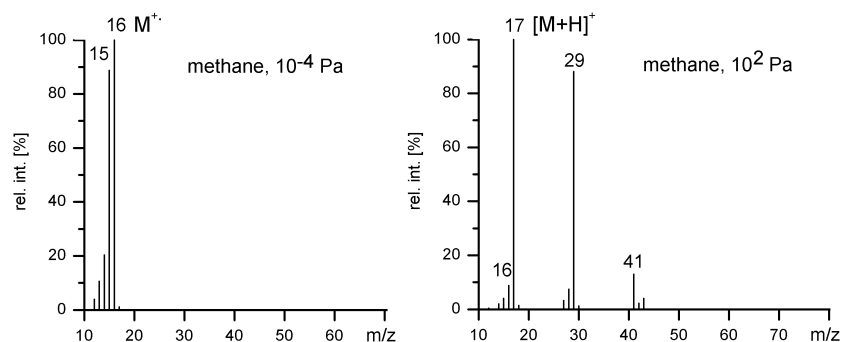

**Fig. 7.2.** Comparison of the methane spectrum upon electron ionization at different ion source pressures: (a) approx. 10<sup>-4</sup> Pa, (b) approx. 10<sup>2</sup> Pa. The latter represents the typical methane reagent gas spectrum in positive-ion CI.

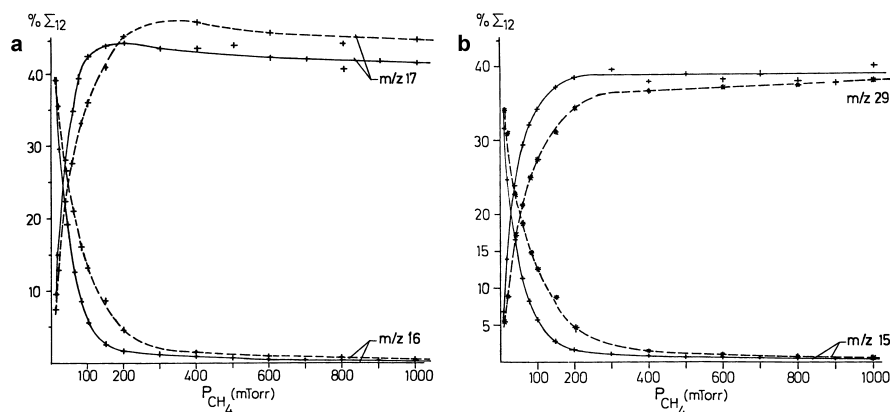
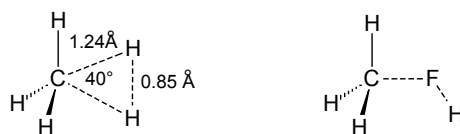

**Fig. 7.3.** Percentage of total ionization above  $m/z$  12 ( $\% \Sigma_{12}$ ) of (a) CH<sub>4</sub><sup>+•</sup>,  $m/z$  16, and CH<sub>5</sub><sup>+</sup>,  $m/z$  17, and (b) CH<sub>3</sub><sup>+</sup>,  $m/z$  15, and C<sub>2</sub>H<sub>5</sub><sup>+</sup>,  $m/z$  29, as a function of CH<sub>4</sub> pressure at 100 eV electron energy and at ion source temperatures 50 °C (—) and 175 °C (----); 100 mTorr = 13.33 Pa. Adapted from Ref. [19] by permission. © Elsevier Science, 1990.

### 7.2.2.1 CH<sub>5</sub><sup>+</sup> and Related Ions

The protonated methane ion, CH<sub>5</sub><sup>+</sup>, represents a reactive as well as fascinating species in the methane reagent gas plasma. Its structure has been calculated and experimentally verified. [16] The chemical behavior of the CH<sub>5</sub><sup>+</sup> ion appears to be compatible with a stable structure, involving a three-center two-electron bond associating 2 hydrogens and the carbon atom. Rearrangement of this structure due to exchange between one of these hydrogens and one of the three remaining hydrogens appears to be a fast process that is induced by interactions with the chemical ionization gas. In case of the C<sub>2</sub>H<sub>7</sub><sup>+</sup> intermediate during C<sub>2</sub>H<sub>5</sub><sup>+</sup> ion formation sev-

eral isomerizing structures are discussed. [17,18] In protonated fluoromethane, the conditions are quite different, promoting a weak C–F and a strong F–H bond. [20]



Scheme 7.1.

### 7.2.3 Energetics of Protonation

The tendency of a (basic) molecule B to accept a proton is quantitatively described by its *proton affinity* PA (Chap. 2.11). For such a protonation we have: [3]

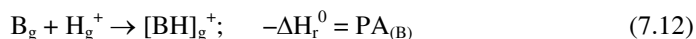

In case of an intended protonation under the conditions of CI one has to compare the PAs of the neutral analyte M with that of the complementary base B of the proton-donating reactant ion  $[BH]^+$  (Brønsted acid). Protonation will occur as long as the process is exothermic, i.e., if  $PA_{(B)} < PA_{(M)}$ . The heat of reaction has basically to be distributed among the degrees of freedom of the  $[M+H]^+$  analyte ion. [12,21] This means in turn, that the minimum internal energy of the  $[M+H]^+$  ions is determined by:

$$E_{\text{int}(M+H)} = -\Delta PA = PA_{(M)} - PA_{(B)} \quad (7.13)$$

Some additional thermal energy will also be contained in the  $[M+H]^+$  ions. Having PA data at hand (Table 2.6) one can easily judge whether a reagent ion will be able to protonate the analyte of interest and how much energy will be put into the  $[M+H]^+$  ion.

**Example:** The  $CH_5^+$  reactant ion will protonate  $C_2H_6$  because Eq. 7.13 gives  $\Delta PA = PA_{(CH_4)} - PA_{(C_2H_6)} = 552 - 601 = -49 \text{ kJ mol}^{-1}$ . The product, protonated ethane,  $C_2H_7^+$ , immediately stabilizes by  $H_2$  loss to yield  $C_2H_5^+$ . [17,18] In case of tetrahydrofuran, protonation is more exothermic:  $\Delta PA = PA_{(CH_4)} - PA_{(C_4H_8O)} = 552 - 831 = -279 \text{ kJ mol}^{-1}$ .

#### 7.2.3.1 Impurities of Higher PA than the Reagent Gas

Due to the above energetic considerations, impurities of the reagent gas having a higher PA than the neutral reagent gas are protonated by the reactant ion. [3] Residual water is a frequent source of contamination. Higher concentrations of water in the reagent gas may even alter its properties completely, i.e.,  $H_3O^+$  becomes the predominant species in a  $CH_4/H_2O$  mixture under CI conditions (Fig. 7.4). [22]

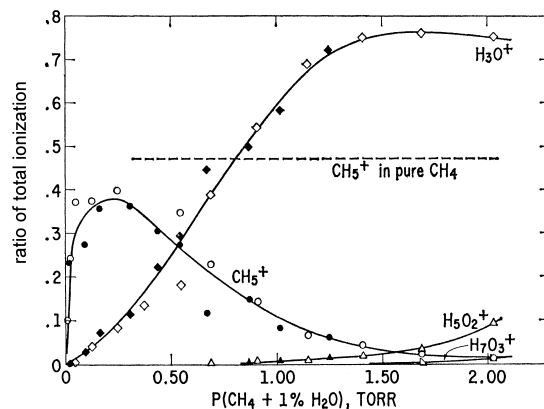

**Fig. 7.4.** Relative concentrations of  $\text{CH}_5^+$  and  $\text{H}_3\text{O}^+$  ions vs. pressure of a mixture of  $\text{CH}_4$  (99 %) and  $\text{H}_2\text{O}$  (1 %). 1 Torr = 133 Pa. Reproduced from Ref. [22] by permission. © American Chemical Society, 1965.

**Note:** Any analyte of suitable PA may be regarded as basic impurity of the reagent gas, and therefore becomes protonated in excellent yield. Heteroatoms and  $\pi$ -electron systems are the preferred sites of protonation. Nevertheless, the additional proton often moves between several positions of the ion, sometimes accompanied by its exchange with otherwise fixed hydrogens. [23,24]

### 7.2.4 Methane Reagent Gas PICI Spectra

The  $[\text{M}+\text{H}]^+$  quasimolecular ion in methane reagent gas PICI spectra – generally denoted *methane-CI spectra* – is usually intense and often represents the base peak. [25-27] Although protonation in CI is generally exothermic by 1–4 eV, the degree of fragmentation of  $[\text{M}+\text{H}]^+$  ions is much lower than that observed for the same analytes under 70 eV EI conditions (Fig. 7.5). This is because  $[\text{M}+\text{H}]^+$  ions have i) a narrow internal energy distribution, and ii) fast radical-induced bond cleavages are prohibited, because solely intact molecules are eliminated from these even-electron ions.

Occasionally, hydride abstraction may occur instead of protonation. Electrophilic addition fairly often gives rise to  $[\text{M}+\text{C}_2\text{H}_5]^+$  and  $[\text{M}+\text{C}_3\text{H}_5]^+$  adduct ions. Thus,  $[\text{M}+29]$  and  $[\text{M}+41]$  peaks are sometimes observed in addition to the expected – usually clearly dominating –  $[\text{M}+1]$  peak.

**Note:** Hydride abstraction is only recognized with some difficulty. To identify a  $[\text{M}-\text{H}]^+$  peak occurring instead of a  $[\text{M}+\text{H}]^+$  peak it is useful to examine the mass differences between the signal in question and the products of electrophilic addition. In such a case,  $[\text{M}+29]$  and  $[\text{M}+41]$  peaks are observed as seemingly  $[\text{M}+31]$  and  $[\text{M}+43]$  peaks, respectively. An apparent loss of 16 u might indicate an  $[\text{M}+\text{H}-\text{H}_2\text{O}]^+$  ion instead of an  $[\text{M}+\text{H}-\text{CH}_4]^+$  ion.

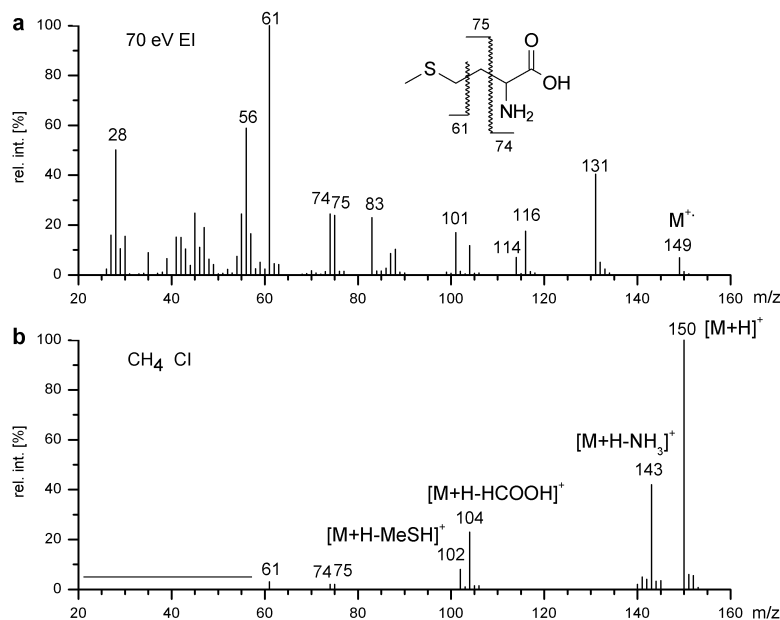
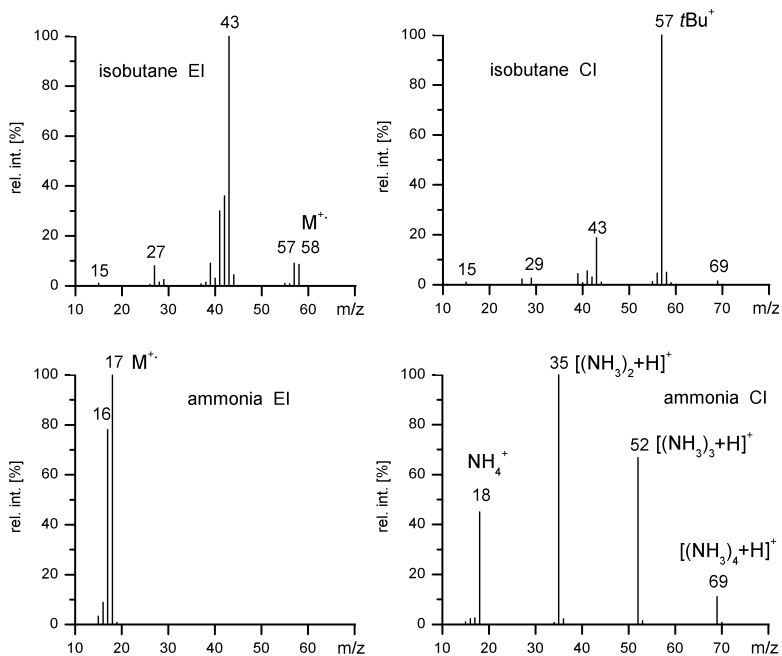

**Fig. 7.5.** Comparison of (a) 70 eV EI spectrum and (b) methane reagent gas CI spectrum of the amino acid methionine. Fragmentation is strongly reduced in the CI mass spectrum.

### 7.2.5 Other Reagent Gases in PICI

As pointed out, the value of  $\Delta PA$  determines whether a particular analyte can be protonated by a certain reactant ion and how exothermic the protonation will be. Considering other reagent gases than methane therefore allows some tuning of the PICI conditions. The systems employed include molecular hydrogen and hydrogen-containing mixtures, [12,21,28] isobutane, [29-33] ammonia, [30,34-40] dimethylether, [41] diisopropylether, [42] acetone, [11] acetaldehyde, [11], benzene, [43] and iodomethane. [44] Even transition metal ions such as  $Cu^+$  [45] and  $Fe^+$  [46] can be employed as reactant ions to locate double bonds. However, nitrous oxide reagent gas better serves that purpose. [39,47,48] The most common reagent gases are summarized in Table 7.1. The EI and CI spectra of ammonia and isobutane are compared in Fig. 7.6.

Isobutane is an especially versatile reagent gas, because i) it provides low-fragmentation PICI spectra of all but the most unpolar analytes, ii) gives almost exclusively one well-defined adduct ( $[M+C_4H_9]^+$ ,  $[M+57]$ ) if any (Fig. 7.7), and iii) can also be employed for electron capture (Chap. 7.4).



**Fig. 7.6.** Standard EI versus positive-ion CI spectra of isobutane (upper) and ammonia (lower part). Ammonia forms abundant cluster ions upon CI.

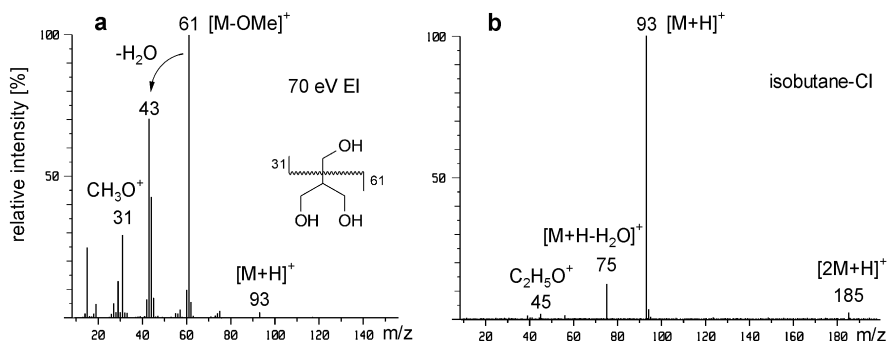

**Fig. 7.7.** Comparison of (a) 70 eV EI and (b) isobutane-CI spectrum of glycerol. Instead of a molecular ion, an [M+H]<sup>+</sup> quasimolecular ion is observed in EI mode, too. In addition to [M+H]<sup>+</sup>, the CI spectrum shows few fragment ions and a weak [2M+H]<sup>+</sup> cluster ion signal.

**Example:** In an overdose case where evidence was available for the ingestion of Percodan (a mixture of several common drugs) the isobutane-CI mass spectrum of the gastric extract was obtained (Fig. 7.8). [29] All drugs give rise to an [M+H]<sup>+</sup> ion. Due to the low exothermicity of protonation by the *tert*-C<sub>4</sub>H<sub>9</sub><sup>+</sup> ion, most [M+H]<sup>+</sup> ions do not show fragmentation. Solely that of aspirin shows intense

fragment ion peaks that can be assigned as  $[M+H-H_2O]^+$ ,  $m/z$  163;  $[M+H-H_2C=CO]^+$ ,  $m/z$  139; and  $[M+H-CH_3COOH]^+$ ,  $m/z$  121. In addition to the  $[M+H]^+$  ion at  $m/z$  180, phenacetin forms a  $[2M+H]^+$  cluster ion,  $m/z$  359. Such  $[2M+H]^+$  cluster ions are frequently observed in CI-MS.

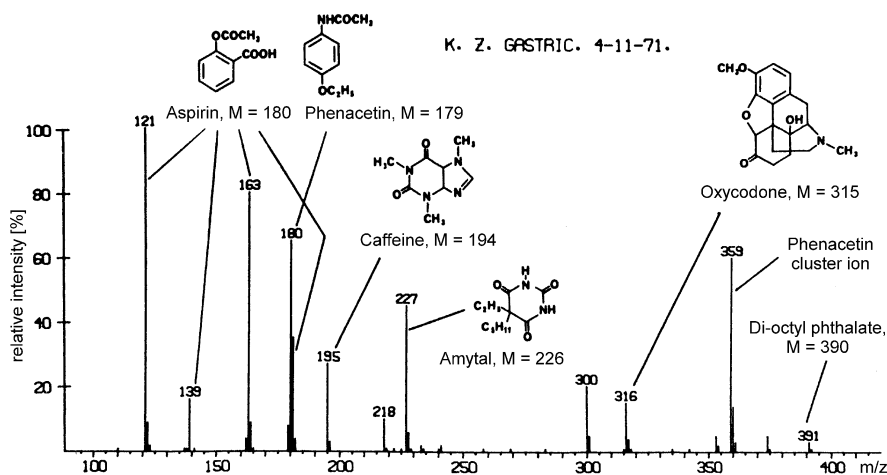

**Fig. 7.8.** Isobutane CI mass spectrum of gastric contents in an overdose case. Reproduced from Ref. [29] by permission. © American Chemical Society, 1970.

**Table 7.1.** Common PICI reagent gases

Reagent Gas	Reactant Ions	Neutral from Reactant Ions	PA of Neutral Product	Analyte Ions
H <sub>2</sub>	H <sub>3</sub> <sup>+</sup>	H <sub>2</sub>	424	$[M+H]^+$ , $[M-H]^+$
CH <sub>4</sub>	CH <sub>5</sub> <sup>+</sup> , (C <sub>2</sub> H <sub>5</sub> <sup>+</sup> and C <sub>3</sub> H <sub>5</sub> <sup>+</sup> )	CH <sub>4</sub>	552	$[M+H]^+$ ( $[M+C_2H_5]^+$ and $[M+C_3H_5]^+$ )
<i>i</i> -C <sub>4</sub> H <sub>10</sub>	<i>t</i> -C <sub>4</sub> H <sub>9</sub> <sup>+</sup>	<i>i</i> -C <sub>4</sub> H <sub>8</sub>	820	$[M+H]^+$ , ( $[M+C_4H_9]^+$ , eventually $[M+C_3H_3]^+$ , $[M+C_3H_5]^+$ and $[M+C_3H_7]^+$ )
NH <sub>3</sub>	NH <sub>4</sub> <sup>+</sup>	NH <sub>3</sub>	854	$[M+H]^+$ , $[M+NH_4]^+$

**Note:** Resulting from the large excess of the reagent gas, its spectrum is of much higher intensity than that of the analyte. Therefore, CI spectra are usually acquired starting above the  $m/z$  range occupied by reagent ions, e.g., above  $m/z$  50 for methane or above  $m/z$  70 for isobutane.

## 7.3 Charge Exchange Chemical Ionization

*Charge exchange* (CE) or *charge transfer ionization* occurs when an ion-neutral reaction takes place in which the ionic charge is transferred to the neutral. [8] In principle, any of the reagent systems discussed so far is capable to effect CE because the respective reagent molecular ions  $X^{+}$  are also present in the plasma:



However, other processes, in particular proton transfer, are prevailing with methane, isobutane, and ammonia, for example. Reagent gases suitable for CE should exhibit abundant molecular ions even under the conditions of CI, whereas potentially protonating species have to be absent or at least of minor abundance.

**Note:** The acronym CE is also used for *capillary electrophoresis*, a separation method. CE may be coupled to a mass spectrometer via an electrospray interface (Chaps. 11, 12), and thus CE-CI and CE-ESI-MS must not be confused.

### 7.3.1 Energetics of CE

The energetics of CE are determined by the ionization energy (IE) of the neutral analyte,  $IE_{(M)}$ , and the *recombination energy* of the reactant ion,  $RE_{(X^{+})}$ . Recombination of an atomic or molecular ion with a free electron is the inverse of its ionization.  $RE_{(X^{+})}$  is defined as the exothermicity of the gas phase reaction: [7]

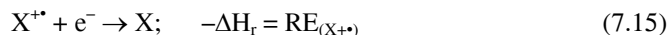

For monoatomic ions, the RE has the same numerical value as the IE of the neutral; for diatomic or polyatomic species differences due to storage of energy in internal modes or electronic excitation may occur. Ionization of the analyte via CE is effected if: [49]

$$RE_{(X^{+})} - IE_{(M)} > 0 \quad (7.16)$$

Now, the heat of reaction, and thus the minimum internal energy of the analyte molecular ion, is given by: [50]

$$E_{\text{int}(M^{+})} \geq RE_{(X^{+})} - IE_{(M)} \quad (7.17)$$

(The  $\geq$  sign indicates the additional contribution of thermal energy.) In summary, no CE is expected if  $RE_{(X^{+})}$  is less than  $IE_{(M)}$ ; predominantly  $M^{+}$  ions are expected if  $RE_{(X^{+})}$  is slightly above  $IE_{(M)}$ ; and extensive fragmentation will be observed if  $RE_{(X^{+})}$  is notably greater than  $IE_{(M)}$ . [50] Accordingly, the “softness” of CE-CI can be adjusted by choosing a reagent gas of suitable RE. Fortunately, the differences between REs and IEs are small, and unless highest accuracy is required, IE data may be used to estimate the effect of a CE reagent gas (Table 2.1).

### 7.3.2 Reagent Gases for CE-CI

The gases employed for CE-CI are numerous. Reagent gases such as hydrogen [21] or methane can also affect CE. Typically, pure compounds are employed as CE reagent gases, but occasionally they are diluted with nitrogen to act as an inert or sometimes reactive buffer gas (Table 7.2). Compared to protonating CI conditions, the reagent gas is typically admitted at somewhat lower pressure (15–80 Pa). Primary electron energies are reported in the 100–600 eV range. The major reagent gases include chlorobenzene, [51] benzene, [43,52,53] carbon disulfide, [54,55] xenon, [54,56] carbon oxysulfide, [54–58] carbon monoxide, [50,54,56] nitrogen oxide, [50,59] dinitrogen oxide, [55,59] nitrogen, [54] and argon. [54]

**Example:** The CE-CI spectra of cyclohexene are compared to the 70 eV EI spectrum. Different CE reagent gases show different degrees of fragmentation (Fig. 7.9). [61] The relative intensity of the molecular ion increases as the RE of the reagent gas decreases. CE-CI mass spectra closely resemble low-energy EI spectra (Chap. 5.1.5) because molecular ions are formed upon CE. As the sensitivity of CE-CI is superior to low-energy EI [49], CE-CI may be preferred over low-energy EI.

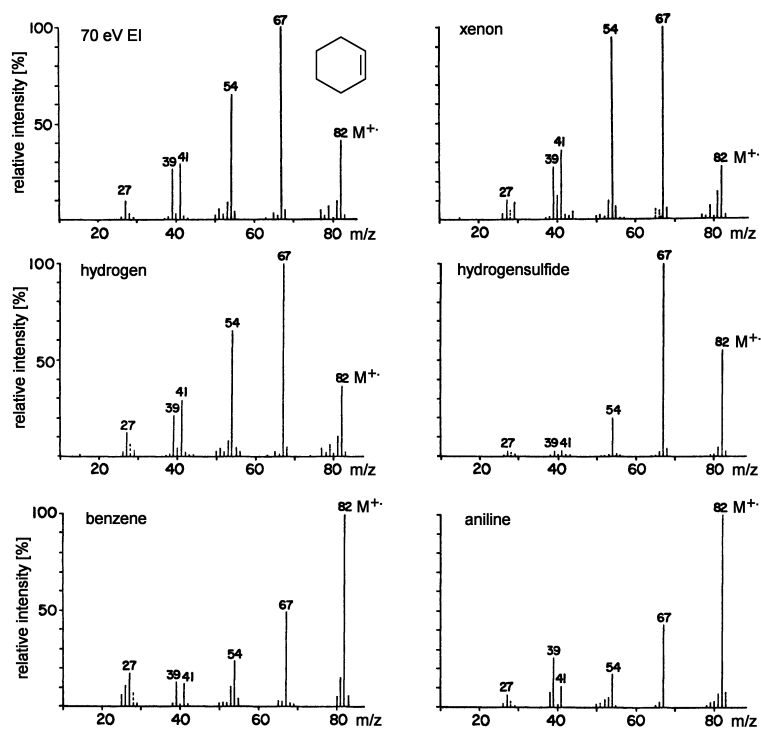

**Fig. 7.9.** Comparison of 70 eV EI mass spectrum and CE mass spectra of cyclohexene recorded with different reagent gases. Adapted from Ref. [61] by permission. © John Wiley & Sons, 1976.

**Table 7.2.** Compilation of CE-CI reagent gases [7,50,51,54-56,60]

Reagent Gas	Reactant Ion	RE or RE range [eV]
C <sub>6</sub> H <sub>5</sub> NH <sub>2</sub>	C <sub>6</sub> H <sub>5</sub> NH <sub>2</sub> <sup>+</sup>	7.7
C <sub>6</sub> H <sub>5</sub> Cl	C <sub>6</sub> H <sub>5</sub> Cl <sup>+</sup>	9.0
C <sub>6</sub> H <sub>6</sub>	C <sub>6</sub> H <sub>6</sub> <sup>+</sup>	9.2
NO <sup>+</sup> : N <sub>2</sub> = 1 : 9	NO <sup>+</sup>	9.3
C <sub>6</sub> F <sub>6</sub> : CO <sub>2</sub> = 1 : 9	C <sub>6</sub> F <sub>6</sub> <sup>+</sup>	10.0
CS <sub>2</sub> : N <sub>2</sub> = 1 : 9	CS <sub>2</sub> <sup>+</sup>	9.5–10.2
H <sub>2</sub> S	H <sub>2</sub> S <sup>+</sup>	10.5
COS : CO = 1 : 9	COS <sup>+</sup>	11.2
Xe	Xe <sup>+</sup>	12.1, 13.4
N <sub>2</sub> O ( : N <sub>2</sub> = 1 : 9)	N <sub>2</sub> O <sup>+</sup>	12.9
CO <sub>2</sub>	CO <sub>2</sub> <sup>+</sup>	13.8
CO	CO <sup>+</sup>	14.0
Kr	Kr <sup>+</sup>	14.0, 14.7
N <sub>2</sub>	N <sub>2</sub> <sup>+</sup>	15.3
H <sub>2</sub>	H <sub>2</sub> <sup>+</sup>	15.4
Ar	Ar <sup>+</sup>	15.8, 15.9
Ne	Ne <sup>+</sup>	21.6, 21.7
He	He <sup>+</sup>	24.6

### 7.3.4 Compound Class-Selective CE-CI

The energy distribution upon CE largely differs from that obtained upon EI in that the CE process delivers an energetically well-defined ionization of the neutral. Choosing the appropriate reagent gas allows for the selective ionization of a targeted compound class contained in a complicated mixture. [49,51,53,62] The differentiation is possible due to the characteristic range of ionization energies for each compound class. This property of CE-CI can also be applied to construct breakdown graphs from a set of CE-CI mass spectra using reactant ions of stepwise increasing RE<sub>(X<sup>+</sup>)</sub>, e.g., C<sub>6</sub>F<sub>6</sub><sup>+</sup>, CS<sub>2</sub><sup>+</sup>, COS<sup>+</sup>, Xe<sup>+</sup>, N<sub>2</sub>O<sup>+</sup>, CO<sup>+</sup>, N<sub>2</sub><sup>+</sup> (Chap. 2.10.5). [56,60]

**Example:** CE-CI allows for the direct determination of the molecular weight distributions of the major aromatic components in liquid fuels and other petroleum products. [49,51,62] The approach involves selective CE between C<sub>6</sub>H<sub>5</sub>Cl<sup>+</sup> and the substituted benzenes and naphthalenes in the sample. In this application, chlorobenzene also serves as the solvent for the fuel to avoid interferences with residual solvent. Thus, the paraffinic components present in the fuel can be suppressed in the resulting CE-CI mass spectra (Fig. 7.10). [51]

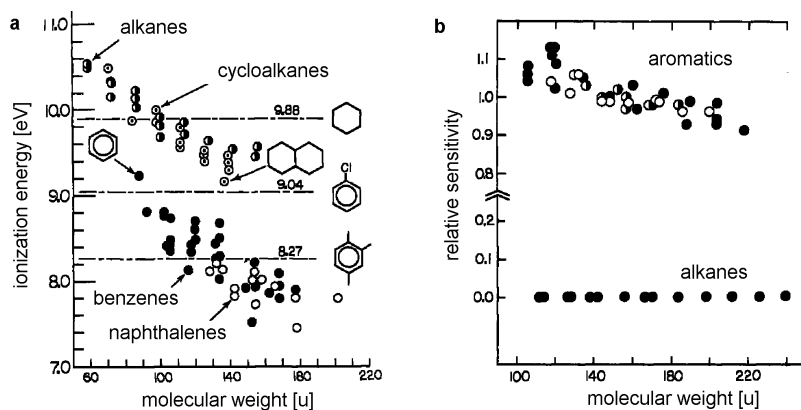
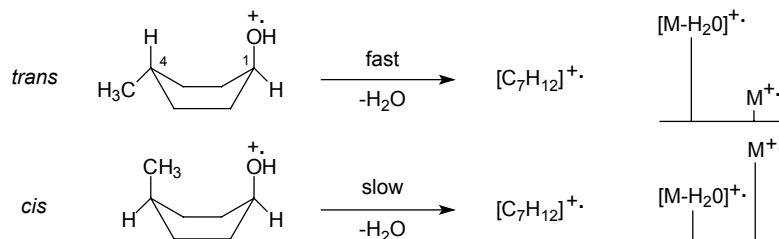

**Fig. 7.10.** (a) Ionization energies of certain classes of organic molecules as a function of their molecular weight, and (b) relative sensitivities for (○) alkylbenzenes, (●) polyolefines, and (◐) substituted naphthalenes in chlorobenzene CE-CI. Adapted from Ref. [51] by permission. © American Chemical Society, 1983.

### 7.3.5 Regio- and Stereoselectivity in CE-CI

Small differences in activation energy (AE) as existing for fragmentations of regioisomers [54,55,57,58] or stereoisomers do not cause significant differences in 70 eV EI spectra. Pathways leading to fragments  $F_1$  and  $F_1'$  cannot be distinguished, because minor differences in the respective AEs are overridden by the excess energy of the fragmenting ions (Chap. 2.5). The situation changes if an energy-tunable ionization method is applied which in addition offers a narrow energy distribution. If the appearance energies  $AE_{(F_1)}$  and  $AE_{(F_1')}$  of the fragments  $F_1$  and  $F_1'$  from isomeric precursor are just below  $RE_{(x^{++})}$ , a significant alteration of relative intensities of  $F_1$  and  $F_1'$  would be effected.

**Example:** In epimeric 4-methylcyclohexanols the methyl and the hydroxyl group can either both reside in axial position (*cis*) or one is equatorial while the other is axial (*trans*). In the *trans* isomer, stereospecific 1,4- $H_2O$  elimination should proceed easily (Chap. 6.10.3), whereas  $H_2O$  loss from the *cis* isomer is more demanding. CE-CI using  $C_6F_6^{++}$  reactant ions clearly distinguishes these stereoisomers by their  $M^{++}/[M-H_2O]^{++}$  ratio (*trans* : *cis* = 0.09 : 2.0 = 23). [60]



**Scheme 7.2.**

## 7.4 Electron Capture

In any CI plasma, both positive and negative ions are formed simultaneously, e.g.,  $[M+H]^+$  and  $[M-H]^-$  ions, and it is just a matter of the polarity of the acceleration voltage which ions are extracted from the ion source. [63] Thus, *negative-ion chemical ionization* (NICI) mass spectra are readily obtained by deprotonation of acidic analytes like phenols or carboxylic acids or by anion attachment. [64-67]

However, one process of negative-ion formation is of special interest, because it provides superior sensitivity with many toxic and/or environmentally relevant substances: [68-72] this is *electron capture* (EC) or *electron attachment*. [73] EC is a resonance process whereby an external electron is incorporated into an orbital of an atom or molecule. [8] Strictly speaking, EC is not a sub-type of CI because the electrons are not provided by a reacting ion, but are freely moving through the gas at thermal energy. Nonetheless, the ion source conditions to achieve EC are similar to PICI. [74]

### 7.4.1 Ion Formation by Electron Capture

When a neutral molecule interacts with an electron of high kinetic energy, the positive radical ion is generated by EI. If the electrons have less energy than the IE of the respective neutral, EI is prohibited. As the electrons approach thermal energy, EC can occur instead. Under EC conditions, there are three different mechanisms of ion formation: [65,75-77]

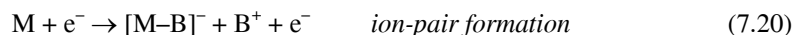

Resonance electron capture directly yields the negative molecular ion,  $M^{\bullet-}$ , whereas even-electron fragment ions are formed by dissociative electron capture and ion-pair formation. Molecular ions are generated by capture of electrons with 0–2 eV kinetic energy, whereas fragment ions are generated by capture of electrons from 0 to 15 eV. Ion-pair formation tends to occur when electron energies exceed 10 eV. [77]

### 7.4.3 Energetics of EC

The potential energy curves of a neutral molecule AB and the potential ionic products from processes 7.18–7.20 are compared below (Fig. 7.11). These graphs reveal that the formation of negative molecular ions,  $AB^{\bullet-}$ , is energetically much more favorable than homolytic bond dissociation of AB and that the  $AB^{\bullet-}$  ions have internal energies close to the activation energy for dissociation. [65,73,75]

The negative molecular ions from EC are therefore definitely less excited than their positive counterparts from 70 eV EI.

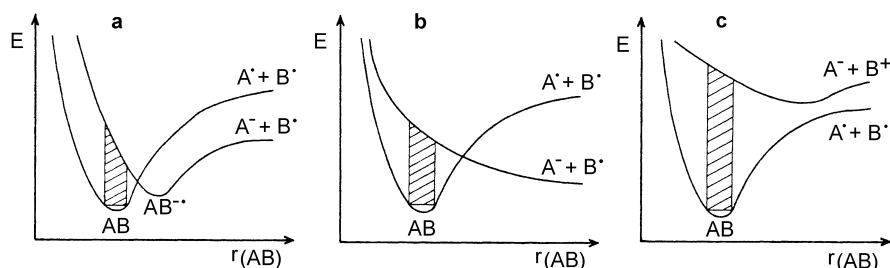

**Fig. 7.11.** Energetics of (a) resonance electron capture, (b) dissociative electron capture, and (c) ion-pair formation. Adapted from Ref. [75] by permission. © John Wiley & Sons, 1981.

**Example:** The EC mass spectrum of benzo[a]pyrene,  $C_{20}H_{12}$ , exclusively shows the negative molecular ion at  $m/z$  252 (Fig. 7.12). The two additional minor signals correspond to impurities of the sample.

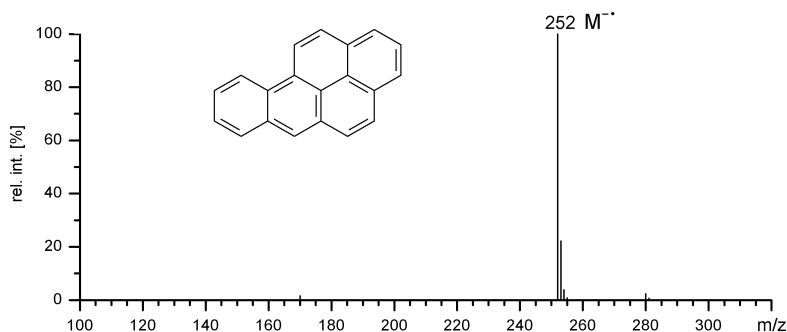

**Fig. 7.12.** EC spectrum of benzo[a]pyrene; isobutane buffer gas, ion source 200 °C.

The energetics of EC are determined by the *electron affinity* (EA) of the neutral. The EA is the negative of the enthalpy of reaction of the attachment of a zero kinetic energy electron to a neutral molecule or atom:



As the IE of a molecule is governed by the atom of lowest IE within that neutral (Chap. 2.2.2), the EA of a molecule is basically determined by the atom of highest electronegativity. This is why the presence of halogens, in particular F and Cl, and nitro groups make analytes become attractive candidates for EC (Table 7.3). [78] If EC occurs with a neutral of negative EA, the electron–molecule complex will have a short lifetime (*autodetachment*), but in case of positive EA a negative molecular ion can persist.

**Example:** Consider the dissociative EC process  $\text{CF}_2\text{Cl}_2 + e^- \rightarrow \text{F}^- + \text{CFCl}_2^-$ . Let the potential energy of  $\text{CF}_2\text{Cl}_2$  be zero. The homolytic bond dissociation energy  $D_{(\text{F}-\text{CFCl}_2)}$  has been calculated as 4.93 eV. Now, the potential energy of the products is 4.93 eV less the electron affinity of a fluorine atom ( $\text{EA}_{(\text{F}^\bullet)} = 3.45$  eV), i.e., the process is endothermic by 1.48 eV. The experimental AE of the fragments is 1.8 eV. This yields a minimum excess energy of 0.32 eV (Fig. 7.13). [79]

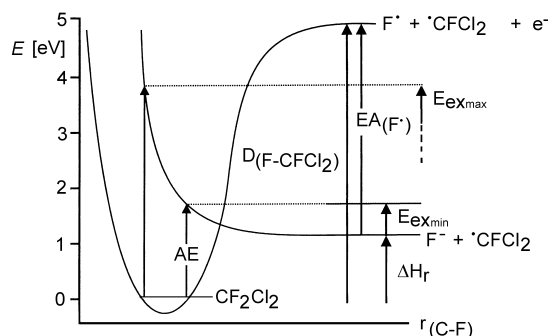

**Fig. 7.13.** Potential energy diagram of dissociative EC process  $\text{CF}_2\text{Cl}_2 + e^- \rightarrow \text{F}^- + \text{CFCl}_2^-$ .

**Table 7.3.** Selected electron affinities [80]

Compound	EA [eV]	Compound	EA [eV]
carbon dioxide	-0.600	pentachlorobenzene	0.729
naphthalene	-0.200	carbon tetrachloride	0.805
acetone	0.002	biphenylene	0.890
1,2-dichlorobenzene	0.094	nitrobenzene	1.006
benzonitrile	0.256	octafluorocyclobutane	1.049
molecular oxygen	0.451	pentafluorobenzonitrile	1.084
carbon disulfide	0.512	2-nitronaphthalene	1.184
benzo[e]pyrene	0.534	1-bromo-4-nitrobenzene	1.292
tetrachloroethylene	0.640	antimony pentafluoride	1.300

#### 7.4.4 Creating Thermal Electrons

Thermionic emission from a heated metal filament is the standard source of free electrons. However, those electrons usually are significantly above thermal energy and need to be decelerated for EC. Buffer gases such as methane, isobutane, or carbon dioxide serve well for that purpose, but others have also been used. [64,74,81] The gases yield almost no negative ions themselves while moderating the energetic electrons to thermal energy. [69] Despite inverse polarity of the extraction voltage, the same conditions as for PICI can usually be applied (Fig. 7.12). However, EC is comparatively sensitive to ion source conditions. [67,82] The actual ion source temperature, the buffer gas, the amount of sample

introduced, and ion source contaminations play important roles each. Regular cleaning of the ion source is important. [70] Lowering the ion source temperature provides lower-energy electrons, e.g., assuming Maxwellian energy distribution the mean electron energy is 0.068 eV at 250 °C and 0.048 eV at 100 °C. [69] Alternatively, electrons of well-defined low energy can be provided by an electron monochromator. [79,82-84]

#### 7.4.5 Appearance of EC Spectra

EC spectra generally exhibit strong molecular ions and some primary fragment ions. As  $M^{\cdot-}$  is an odd-electron species, homolytic bond cleavages as well as rearrangement fragmentations may occur (Fig. 7.14) Apart from the changed charge sign, there are close similarities to the fragmentation pathways of positive molecular ions (Chap. 6.). [67,76,77]

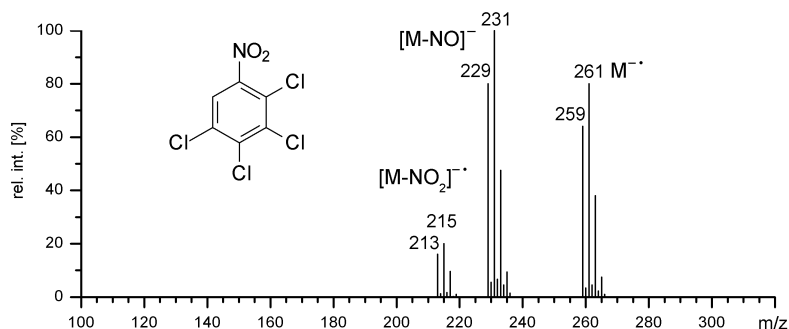

**Fig. 7.14.** Methane EC spectrum of 2,3,4,5-tetrachloronitrobenzene. Redrawn from Ref. [77] by permission. © John Wiley & Sons, 1988.

#### 7.4.6 Applications of EC

EC, especially when combined with GC-MS, is widespread in monitoring environmental pollutants such as toxaphene, [72] dioxins, [74,79,82,84] pesticides, [79] halogenated metabolites, [71] DNA adducts, [78] explosives, [66,85,86] and others. [68,69,87,88]

### 7.5 Sample Introduction in CI

In CI, the analyte is introduced into the ion source the same way as described for EI, i.e., via *direct insertion probe* (DIP), *direct exposure probe* (DEP), *gas chromatograph* (GC), or *reservoir inlet* (Chap. 5.3).

### 7.5.1 Desorption Chemical Ionization

CI in conjunction with a *direct exposure probe* is known as *desorption chemical ionization* (DCI). [30,89,90] In DCI, the analyte is applied from solution or suspension to the outside of a thin resistively heated wire loop or coil. Then, the analyte is directly exposed to the reagent gas plasma while being rapidly heated at rates of several hundred  $^{\circ}\text{C s}^{-1}$  and to temperatures up to about  $1500^{\circ}\text{C}$  (Chap. 5.3.2 and Fig. 5.16). The actual shape of the wire, the method how exactly the sample is applied to it, and the heating rate are of importance for the analytical result. [91,92] The rapid heating of the sample plays an important role in promoting molecular species rather than pyrolysis products. [93] A laser can be used to effect extremely fast evaporation from the probe prior to CI. [94] In case of non-availability of a dedicated DCI probe, a field emitter on a field desorption probe (Chap. 8) might serve as a replacement. [30,95] Different from *desorption electron ionization* (DEI), DCI plays an important role. [92] DCI can be employed to detect arsenic compounds present in the marine and terrestrial environment [96], to determine the sequence distribution of  $\beta$ -hydroxyalkanoate units in bacterial copolyesters [97], to identify additives in polymer extracts [98] and more. [99] Provided appropriate experimental setup, high resolution and accurate mass measurements can also be achieved in DCI mode. [100]

**Example:** DCI requires fast scanning of the mass analyzer because of the rather sudden evaporation of the analyte. The pyrolysis (Py) DCI mass spectrum of cellulose,  $\text{H}(\text{C}_6\text{H}_{10}\text{O}_5)_n\text{OH}$ , acquired using  $\text{NH}_3$  reagent gas, 100 eV electron energy, and scanning  $m/z$  140–700 at 2 s per cycle shows a series of distinct signals. The peaks are separated by 162 u, i.e., by  $\text{C}_6\text{H}_{10}\text{O}_5$  saccharide units. The main signals are due to ions from anhydro-oligosaccharides,  $[(\text{C}_6\text{H}_{10}\text{O}_5)_n + \text{NH}_4]^+$ , formed upon heating of the cellulose in the ammonia CI plasma (Fig. 7.15). [91]

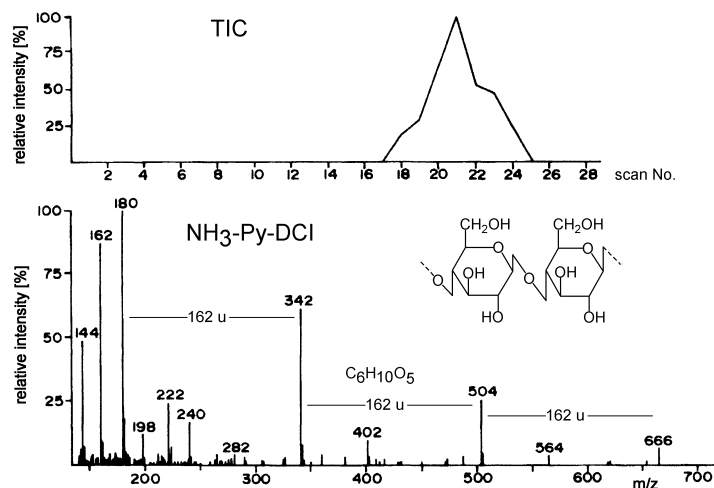

**Fig. 7.15.** Ammonia-Py-DCI mass spectrum of cellulose and total ion current. Adapted from Ref. [91] by permission. © Research Council of Canada, 1994.

**Note:** Although *desorption chemical ionization* being the correct term, [92] DCI is sometimes called *direct CI*, *direct exposure CI*, *in-beam CI*, or even *surface ionization* in the literature.

## 7.6 Analytes for CI

Whether an analyte is suitable to be analyzed by CI depends on what particular CI technique is to be applied. Obviously, protonating PICI will be beneficial for other compounds than CE-CI or EC. In general, most analytes accessible to EI (Chap. 5.6) can be analyzed by protonating PICI, and PICI turns out to be especially useful when molecular ion peaks in EI are absent or very weak. CE-CI and EC play a role where selectivity and/or very high sensitivity for a certain compound class is desired (Table 7.4). The typical mass range for CI reaches from 80 to 1200 u. In DCI, molecules up to 2000 u are standard, but up to 6000 u may become feasible. [92]

**Table 7.4.** CI methods for different groups of analytes

Analyte	Thermodynamic Properties <sup>a)</sup>	Example	Suggested CI Method
low polarity, no heteroatoms	low to high IE, low PA, low EA	alkanes, alkenes, aromatic hydrocarbons	CE
low to medium polarity, one or two heteroatoms	low to medium IE, medium to high PA, low EA	alcohols, amines, esters, heterocyclic compounds	PICI, CE
medium to high polarity, some heteroatoms	low to medium IE, high PA and low EA	diols, triols, amino acids, disaccharides, substituted aromatic or heterocyclic compounds	PICI
low to high polarity, halogens (especially F or Cl)	medium IE, low PA, medium to high EA	halogenated compounds, derivatives, e.g., trifluoroacetate, pentafluorobenzyl	EC
high polarity, medium to high molecular mass	low to medium IE, high PA and low EA	mono- to tetrasaccharides, low mass peptides, other polar oligomers	DCI
high polarity, very high molecular mass	decomposition products of low to medium IE, high PA and low EA	polysaccharides, humic compounds, synthetic polymers	Py-DCI

a) IE: ionization energy, PA: proton affinity, EA: electron affinity

## 7.7 Mass Analyzers for CI

For the choice of a mass analyzer to be operated with a CI ion source the same criteria as for EI apply (Chap. 5.5). As mentioned before, sufficient pumping speed at the ion source housing is a prerequisite.

### Reference List

1. Talrose, V.L.; Ljubimova, A.K. Secondary Processes in the Ion Source of a Mass Spectrometer (Reprint From 1952). *J. Mass Spectrom.* **1998**, *33*, 502-504.
2. Munson, M.S.B.; Field, F.H. Reactions of Gaseous Ions. XV. Methane + 1% Ethane and Methane + 1% Propane. *J. Am. Chem. Soc.* **1965**, *87*, 3294-3299.
3. Munson, M.S.B. Proton Affinities and the Methyl Inductive Effect. *J. Am. Chem. Soc.* **1965**, *87*, 2332-2336.
4. Munson, M.S.B.; Field, F.H. Chemical Ionization Mass Spectrometry. I. General Introduction. *J. Am. Chem. Soc.* **1966**, *88*, 2621-2630.
5. Munson, M.S.B. Development of Chemical Ionization Mass Spectrometry. *Int. J. Mass Spectrom.* **2000**, *200*, 243-251.
6. Richter, W.J.; Schwarz, H. Chemical Ionization - a Highly Important Productive Mass Spectrometric Analysis Method. *Angew. Chem.* **1978**, *90*, 449-469.
7. Harrison, A.G. *Chemical Ionization Mass Spectrometry*; 2nd ed.; CRC Press: Boca Raton, 1992.
8. Todd, J.F.J. Recommendations for Nomenclature and Symbolism for Mass Spectroscopy Including an Appendix of Terms Used in Vacuum Technology. *Int. J. Mass Spectrom. Ion. Proc.* **1995**, *142*, 211-240.
9. Griffith, K.S.; Gellene, G.I. A Simple Method for Estimating Effective Ion Source Residence Time. *J. Am. Soc. Mass Spectrom.* **1993**, *4*, 787-791.
10. Field, F.H.; Munson, M.S.B. Reactions of Gaseous Ions. XIV. Mass Spectrometric Studies of Methane at Pressures to 2 Torr. *J. Am. Chem. Soc.* **1965**, *87*, 3289-3294.
11. Hunt, D.F.; Ryan, J.F.I. Chemical Ionization Mass Spectrometry Studies. I. Identification of Alcohols. *Tetrahedron Lett.* **1971**, *47*, 4535-4538.
12. Herman, J.A.; Harrison, A.G. Effect of Reaction Exothermicity on the Proton Transfer Chemical Ionization Mass Spectra of Isomeric C<sub>5</sub> and C<sub>6</sub> Alkanols. *Can. J. Chem.* **1981**, *59*, 2125-2132.
13. Beggs, D.; Vestal, M.L.; Fales, H.M.; Milne, G.W.A. Chemical Ionization Mass Spectrometer Source. *Rev. Sci. Instr.* **1971**, *42*, 1578-1584.
14. Schröder, E. *Massenspektrometrie - Begriffe und Definitionen*; Springer-Verlag: Heidelberg, 1991.
15. Price, P. Standard Definitions of Terms Relating to Mass Spectrometry. A Report From the Committee on Measurements and Standards of the ASMS. *J. Am. Chem. Soc. Mass Spectrom.* **1991**, *2*, 336-348.
16. Heck, A.J.R.; de Koning, L.J.; Nibbering, N.M.M. Structure of Protonated Methane. *J. Am. Soc. Mass Spectrom.* **1991**, *2*, 454-458.
17. Mackay, G.I.; Schiff, H.I.; Bohme, K.D. A Room-Temperature Study of the Kinetics and Energetics for the Protonation of Ethane. *Can. J. Chem.* **1981**, *59*, 1771-1778.
18. Fisher, J.J.; Koyanagi, G.K.; McMahon, T.B. The C<sub>2</sub>H<sub>7</sub><sup>+</sup> Potential Energy Surface: a Fourier Transform Ion Cyclotron Resonance Investigation of the Reaction of Methyl Cation with Methane. *Int. J. Mass Spectrom.* **2000**, *195/196*, 491-505.
19. Drabner, G.; Poppe, A.; Budzikiewicz, H. The Composition of the Methane Plasma. *Int. J. Mass Spectrom. Ion Proc.* **1990**, *97*, 1-33.
20. Heck, A.J.R.; de Koning, L.J.; Nibbering, N.M.M. On the Structure and Unimolecular Chemistry of Protonated Halomethanes. *Int. J. Mass Spectrom. Ion Proc.* **1991**, *109*, 209-225.
21. Herman, J.A.; Harrison, A.G. Effect of Protonation Exothermicity on the CI Mass Spectra of Some Alkylbenzenes. *Org. Mass Spectrom.* **1981**, *16*, 423-427.
22. Munson, M.S.B.; Field, F.H. Reactions of Gaseous Ions. XVI. Effects of Additives

- on Ionic Reactions in Methane. *J. Am. Chem. Soc.* **1965**, *87*, 4242-4247.
23. Kuck, D.; Petersen, A.; Fastabend, U. Mobile Protons in Large Gaseous Alkylbenzenium Ions. The 21-Proton Equilibration in Protonated Tetrabenzylmethane and Related "Proton Dances". *Int. J. Mass Spectrom.* **1998**, *179/180*, 129-146.
  24. Kuck, D. Half a Century of Scrambling in Organic Ions: Complete, Incomplete, Progressive and Composite Atom Interchange. *Int. J. Mass Spectrom.* **2002**, *213*, 101-144.
  25. Fales, H.M.; Milne, G.W.A.; Axenrod, T. Identification of Barbiturates by CI-MS. *Anal. Chem.* **1970**, *42*, 1432-1435.
  26. Milne, G.W.A.; Axenrod, T.; Fales, H.M. CI-MS of Complex Molecules. IV. Amino Acids. *J. Am. Chem. Soc.* **1970**, *92*, 5170-5175.
  27. Fales, H.M.; Milne, G.W.A. CI-MS of Complex Molecules. II. Alkaloids. *J. Am. Chem. Soc.* **1970**, *92*, 1590-1597.
  28. Herman, J.A.; Harrison, A.G. Energetics and Structural Effects in the Fragmentation of Protonated Esters in the Gas Phase. *Can. J. Chem.* **1981**, *59*, 2133-2145.
  29. Milne, G.W.A.; Fales, H.M.; Axenrod, T. Identification of Dangerous Drugs by Isobutane CI-MS. *Anal. Chem.* **1970**, *42*, 1815-1820.
  30. Takeda, N.; Harada, K.-I.; Suzuki, M.; Tatematsu, A.; Kubodera, T. Application of Emitter CI-MS to Structural Characterization of Aminoglycoside Antibiotics. *Org. Mass Spectrom.* **1982**, *17*, 247-252.
  31. McGuire, J.M.; Munson, B. Comparison of Isopentane and Isobutane as Chemical Ionization Reagent Gases. *Anal. Chem.* **1985**, *57*, 680-683.
  32. McCamish, M.; Allan, A.R.; Roboz, J. Poly(Dimethylsiloxane) As Mass Reference for Accurate Mass Determination in Isobutane CI-MS. *Rapid Commun. Mass Spectrom.* **1987**, *1*, 124-125.
  33. Maeder, H.; Gunzelmann, K.H. Straight-Chain Alkanes As Reference Compounds for Accurate Mass Determination in Isobutane CI-MS. *Rapid Commun. Mass Spectrom.* **1988**, *2*, 199-200.
  34. Hunt, D.F.; McEwen, C.N.; Upham, R.A. CI-MS II. Differentiation of Primary, Secondary, and Tertiary Amines. *Tetrahedron Lett.* **1971**, *47*, 4539-4542.
  35. Keough, T.; DeStefano, A.J. Factors Affecting Reactivity in Ammonia CI-MS. *Org. Mass Spectrom.* **1981**, *16*, 527-533.
  36. Hancock, R.A.; Hodges, M.G. A Simple Kinetic Method for Determining Ion-Source Pressures for Ammonia CI-MS. *Int. J. Mass Spectrom. Ion Phys.* **1983**, *46*, 329-332.
  37. Rudewicz, P.; Munson, B. Effect of Ammonia Partial Pressure on the Sensitivities for Oxygenated Compounds in Ammonia CI-MS. *Anal. Chem.* **1986**, *58*, 2903-2907.
  38. Lawrence, D.L. Accurate Mass Measurement of Positive Ions Produced by Ammonia Chemical Ionization. *Rapid Commun. Mass Spectrom.* **1990**, *4*, 546-549.
  39. Busker, E.; Budzikiewicz, H. Studies in CI-MS. 2. Isobutane and Nitric Oxide Spectra of Alkynes. *Org. Mass Spectrom.* **1979**, *14*, 222-226.
  40. Brinded, K.A.; Tiller, P.R.; Lane, S.J. Triton X-100 As a Reference Compound for Ammonia High-Resolution CI-MS and as a Tuning and Calibration Compound for Thermospray. *Rapid Commun. Mass Spectrom.* **1993**, *7*, 1059-1061.
  41. Wu, H.-F.; Lin, Y.-P. Determination of the Sensitivity of an External Source Ion Trap Tandem Mass Spectrometer Using Dimethyl Ether Chemical Ionization. *J. Mass Spectrom.* **1999**, *34*, 1283-1285.
  42. Barry, R.; Munson, B. Selective Reagents in CI-MS: Diisopropyl Ether. *Anal. Chem.* **1987**, *59*, 466-471.
  43. Allgood, C.; Lin, Y.; Ma, Y.C.; Munson, B. Benzene as a Selective Chemical Ionization Reagent Gas. *Org. Mass Spectrom.* **1990**, *25*, 497-502.
  44. Srinivas, R.; Vairamani, M.; Mathews, C.K. Gase-Phase Halo Alkylation of C<sub>60</sub>-Fullerene by Ion-Molecule Reaction Under Chemical Ionization. *J. Am. Soc. Mass Spectrom.* **1993**, *4*, 894-897.
  45. Fordham, P.J.; Chamot-Rooke, J.; Guidice, E.; Tortajada, J.; Morizur, J.-P. Analysis of Alkenes by Copper Ion Chemical Ionization Gas Chromatography/Mass Spectrometry and Gas Chromatography/Tandem Mass Spectrometry. *J. Mass Spectrom.* **1999**, *34*, 1007-1017.
  46. Peake, D.A.; Gross, M.L. Iron(I) Chemical Ionization and Tandem Mass Spectrometry for Locating Double Bonds. *Anal. Chem.* **1985**, *57*, 115-120.
  47. Budzikiewicz, H.; Blech, S.; Schneider, B. Studies in Chemical Ionization. XXVI. Investigation of Aliphatic Dienes by Chemical Ionization With Nitric Oxide. *Org. Mass Spectrom.* **1991**, *26*, 1057-1060.

48. Schneider, B.; Budzikiewicz, H. A Facile Method for the Localization of a Double Bond in Aliphatic Compounds. *Rapid Commun. Mass Spectrom.* **1990**, *4*, 550-551.
49. Hsu, C.S.; Qian, K. Carbon Disulfide CE-MS as a Low-Energy Ionization Technique for Hydrocarbon Characterization. *Anal. Chem.* **1993**, *65*, 767-771.
50. Einolf, N.; Munson, B. High-Pressure CE-MS. *Int. J. Mass Spectrom. Ion Phys.* **1972**, *9*, 141-160.
51. Sieck, L.W. Determination of Molecular Weight Distribution of Aromatic Components in Petroleum Products by CI-MS with Chlorobenzene As Reagent Gas. *Anal. Chem.* **1983**, *55*, 38-41.
52. Allgood, C.; Ma, Y.C.; Munson, B. Quantitation Using Benzene in Gas Chromatography/CI-MS. *Anal. Chem.* **1991**, *63*, 721-725.
53. Subba Rao, S.C.; Fenselau, C. Evaluation of Benzene As a Charge Exchange Reagent. *Anal. Chem.* **1978**, *50*, 511-515.
54. Li, Y.H.; Herman, J.A.; Harrison, A.G. CE Mass Spectra of Some C<sub>5</sub>H<sub>10</sub> Isomers. *Can. J. Chem.* **1981**, *59*, 1753-1759.
55. Abbatt, J.A.; Harrison, A.G. Low-Energy Mass Spectra of Some Aliphatic Ketones. *Org. Mass Spectrom.* **1986**, *21*, 557-563.
56. Herman, J.A.; Li, Y.-H.; Harrison, A.G. Energy Dependence of the Fragmentation of Some Isomeric C<sub>6</sub>H<sub>12</sub><sup>+</sup> Ions. *Org. Mass Spectrom.* **1982**, *17*, 143-150.
57. Chai, R.; Harrison, A.G. Location of Double Bonds by CI-MS. *Anal. Chem.* **1981**, *53*, 34-37.
58. Keough, T.; Mihelich, E.D.; Eickhoff, D.J. Differentiation of Monoepoxide Isomers of Polyunsaturated Fatty Acids and Fatty Acid Esters by Low-Energy CE-MS. *Anal. Chem.* **1984**, *56*, 1849-1852.
59. Polley, C.W., Jr.; Munson, B. Nitrous Oxide As Reagent Gas for Positive Ion Chemical Ionization Mass Spectrometry. *Anal. Chem.* **1983**, *55*, 754-757.
60. Harrison, A.G.; Lin, M.S. Stereochemical Applications of Mass Spectrometry. 3. Energy Dependence of the Fragmentation of Stereoisomeric Methylcyclohexanols. *Org. Mass Spectrom.* **1984**, *19*, 67-71.
61. Hsu, C.S.; Cooks, R.G. CE-MS at High Energy. *Org. Mass Spectrom.* **1976**, *11*, 975-983.
62. Roussis, S. Exhaustive Determination of Hydrocarbon Compound Type Distributions by High Resolution Mass Spectrometry. *Rapid Commun. Mass Spectrom.* **1999**, *13*, 1031-1051.
63. Hunt, D.F.; Stafford, G.C., Jr.; Crow, F.W. Pulsed Positive- and Negative-Ion CI-MS. *Anal. Chem.* **1976**, *48*, 2098-2104.
64. Dougherty, R.C.; Weisenberger, C.R. Negative Ion Mass Spectra of Benzene, Naphthalene, and Anthracene. A New Technique for Obtaining Relatively Intense and Reproducible Negative Ion Mass Spectra. *J. Am. Chem. Soc.* **1968**, *90*, 6570-6571.
65. Dillard, J.G. Negative Ion Mass Spectrometry. *Chem. Rev.* **1973**, *73*, 589-644.
66. Bouma, W.J.; Jennings, K.R. Negative CI-MS of Explosives. *Org. Mass Spectrom.* **1981**, *16*, 330-335.
67. Budzikiewicz, H. Studies in Negative Ion Mass Spectrometry. XI. Negative Chemical Ionization (NCI) of Organic Compounds. *Mass Spectrom. Rev.* **1986**, *5*, 345-380.
68. Hunt, D.F.; Crow, F.W. Electron Capture Negative-Ion CI-MS. *Anal. Chem.* **1978**, *50*, 1781-1784.
69. Ong, V.S.; Hites, R.A. Electron Capture Mass Spectrometry of Organic Environmental Contaminants. *Mass Spectrom. Rev.* **1994**, *13*, 259-283.
70. Oehme, M. Quantification of fg-pg Amounts by Electron Capture Negative Ion Mass Spectrometry - Parameter Optimization and Practical Advice. *Fresenius J. Anal. Chem.* **1994**, *350*, 544-554.
71. Bartels, M.J. Quantitation of the Tetrachloroethylene Metabolite *N*-Acetyl-*S*-(trichlorovinyl)cysteine in Rat Urine Via Negative Ion Chemical Ionization Gas Chromatography/Tandem Mass Spectrometry. *Biol. Mass Spectrom.* **1994**, *23*, 689-694.
72. Fowler, B. The Determination of Toxaphene in Environmental Samples by Negative Ion Electron Capture (EC) HR-MS. *Chemosphere* **2000**, *41*, 487-492.
73. von Ardenne, M.; Steinfelder, K.; Tümmler, R. *Elektronenanlagerungs-Massenspektrographie Organischer Substanzen*; Springer-Verlag: Heidelberg, 1971.
74. Laramée, J.A.; Arbogast, B.C.; Deinzer, M.L. EC Negative Ion CI-MS of 1,2,3,4-Tetrachlorodibenzo-*p*-dioxin. *Anal. Chem.* **1986**, *58*, 2907-2912.
75. Budzikiewicz, H. Mass Spectrometry of Negative Ions. 3. Mass Spectrometry of

- Negative Organic Ions. *Angew. Chem.* **1981**, *93*, 635-649.
76. Bowie, J.H. The Formation and Fragmentation of Negative Ions Derived From Organic Molecules. *Mass Spectrom. Rev.* **1984**, *3*, 161-207.
77. Stemmler, E.A.; Hites, R.A. The Fragmentation of Negative Ions Generated by EC Negative Ion Mass Spectrometry: a Review With New Data. *Biomed. Environ. Mass Spectrom.* **1988**, *17*, 311-328.
78. Giese, R.W. Detection of DNA Adducts by Electron Capture Mass Spectrometry. *Chem. Res. Toxicol.* **1997**, *10*, 255-270.
79. Laramée, J.A.; Mazurkiewicz, P.; Berkout, V.; Deinzer, M.L. Electron Monochromator-Mass Spectrometer for Negative Ion Analysis of Electronegative Compounds. *Mass Spectrom. Rev.* **1996**, *15*, 15-42.
80. NIST, NIST Chemistry Webbook. <http://webbook.nist.gov> **2002**.
81. Williamson, D.H.; Knighton, W.B.; Grimsrud, E.P. Effect of Buffer Gas Alterations on the Thermal Electron Attachment and Detachment Reactions of Azulene by Pulsed High Pressure Mass Spectrometry. *Int. J. Mass Spectrom.* **2000**, *195/196*, 481-489.
82. Carette, M.; Zerega, Y.; Perrier, P.; Andre, J.; March, R.E. Rydberg EC-MS of 1,2,3,4-Tetrachlorodibenzo-*p*-dioxin. *Eur. Mass Spectrom.* **2000**, *6*, 405-408.
83. Wei, J.; Liu, S.; Fedoreyev, S.A.; Vionov, V.G. A Study of Resonance Electron Capture Ionization on a Quadrupole Tandem Mass Spectrometer. *Rapid Commun. Mass Spectrom.* **2000**, *14*, 1689-1694.
84. Zerega, Y.; Carette, M.; Perrier, P.; Andre, J. Rydberg EC-MS of Organic Pollutants. *Organohal. Comp.* **2002**, *55*, 151-154.
85. Yinon, J. Mass Spectrometry of Explosives: Nitro Compounds, Nitrate Esters, and Nitramines. *Mass Spectrom. Rev.* **1982**, *1*, 257-307.
86. Cappiello, A.; Famigliani, G.; Lombardozzi, A.; Massari, A.; Vadalà, G.G. EC Ionization of Explosives With a Microflow Rate Particle Beam Interface. *J. Am. Soc. Mass Spectrom.* **1996**, *7*, 753-758.
87. Knighton, W.B.; Grimsrud, E.P. High-Pressure EC-MS. *Mass Spectrom. Rev.* **1995**, *14*, 327-343.
88. Aubert, C.; Rontani, J.-F. Perfluoroalkyl Ketones: Novel Derivatization Products for the Sensitive Determination of Fatty Acids by Gas GC-MS in EI and NICI Modes. *Rapid Commun. Mass Spectrom.* **2000**, *14*, 960-966.
89. Cotter, R.J. Mass Spectrometry of Non-volatile Compounds by Desorption From Extended Probes. *Anal. Chem.* **1980**, *52*, 1589A-1602A.
90. Kurlansik, L.; Williams, T.J.; Strong, J.M.; Anderson, L.W.; Campana, J.E. DCI-MS of Synthetic Porphyrins. *Biomed. Mass Spectrom.* **1984**, *11*, 475-481.
91. Helleur, R.J.; Thibault, P. Optimization of Pyrolysis-Desorption CI-MS and Tandem Mass Spectrometry of Polysaccharides. *Can. J. Chem.* **1994**, *72*, 345-351.
92. Vincenti, M. The Renaissance of DCI-MS: Characterization of Large Involatile Molecules and Nonpolar Polymers. *Int. J. Mass Spectrom.* **2001**, *212*, 505-518.
93. Beuhler, R.J.; Flanigan, E.; Greene, L.J.; Friedman, L. Proton Transfer MS of Peptides. Rapid Heating Technique for Underivatized Peptides Containing Arginine. *J. Am. Chem. Soc.* **1974**, *96*, 3990-3999.
94. Cotter, R.J. Laser Desorption CI-MS. *Anal. Chem.* **1980**, *52*, 1767-1770.
95. Hunt, D.F.; Shabanowitz, J.; Botz, F.K. CI-MS of Salts and Thermally Labile Organics With Field Desorption Emitters as Solids Probes. *Anal. Chem.* **1977**, *49*, 1160-1163.
96. Cullen, W.R.; Eigendorf, G.K.; Pergantis, S.A. DCI-MS of Arsenic Compounds Present in the Marine and Terrestrial Environment. *Rapid Commun. Mass Spectrom.* **1993**, *7*, 33-36.
97. Abate, R.; Garozzo, D.; Rapisardi, R.; Ballistreri, A.; Montaudo, G. Sequence Distribution of  $\beta$ -Hydroxyalkanoate Units in Bacterial Copolyesters Determined by DCI-MS. *Rapid Commun. Mass Spectrom.* **1992**, *6*, 702-706.
98. Juo, C.G.; Chen, S.W.; Her, G.R. Mass Spectrometric Analysis of Additives in Polymer Extracts by DCI and CID with B/E Linked Scanning. *Anal. Chim. Acta* **1995**, *311*, 153-164.
99. Chen, G.; Cooks, R.G.; Jha, S.K.; Green, M.M. Microstructure of Alkoxy and Alkyl Substituted Isocyanate Copolymers Determined by DCI-MS. *Anal. Chim. Acta* **1997**, *356*, 149-154.
100. Pergantis, S.A.; Emond, C.A.; Madilao, L.L.; Eigendorf, G.K. Accurate Mass Measurements of Positive Ions in the DCI Mode. *Org. Mass Spectrom.* **1994**, *29*, 439-444.